



◆ ALWAYS
IN SEASON ◆

**2016-2017
Merchandising
Catalog**







HOLA

Increase display space and sales

Increase display space and sales with innovation from the #1 selling brand of avocados in the U.S.

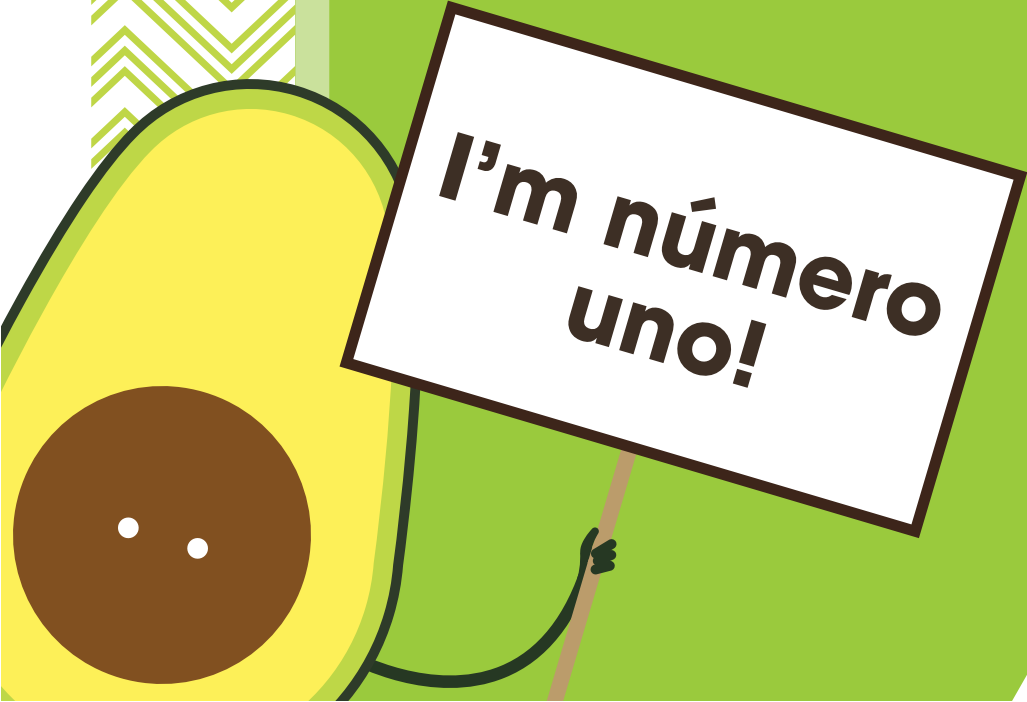

I'm número uno!



ALWAYS
IN SEASON

portable display

LA0147 Perm Rolling Rack

Assembled Dimension:
22.56" w x 18.8" d x 65" h

Assembled Dimension w/o Header:
22.56" w x 18.8" d x 48.75" h

Fill Capacity:
5-6 48ct cases

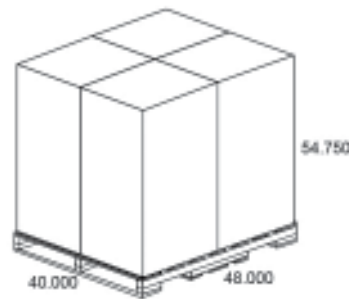

Pallet Layout

Features & Specifications:

- Permanent display is durable for long lasting life
- Ease of execution, displays arrive per-assemble, simply attach header in store
- Multi SKU ability offering "unlimited" placement in store and cross merchandising
- Design protects product from bruising and damage
- Excellent product visible
- Easy to shop & restock
- Rolling rear casters allow the display to lean back to be easily moved in store
- "Flat-back" design of two racks / positioned back to back creates a double-sided display
- Optional plastic bag dispenser available

Header available in 5 different custom signs (see page 14).



portable display

LA0652 Eco-Friendly Display

Assembled Dimension:
18.5" w x 14.5" d x 68" h

Assembled Dimension w/o Header:
18.5" w x 14.5" d x 50" h

Fill Capacity:
4-5 48ct cases



Pallet Layout

features & Specifications:

- 15 kits on 48" x 40" x 75" h pallet
- Easy to assemble and break down for recycling in minutes
- Made from 100% recyclable corrugated material
- High density laminated fiber board extends in store life
- Robust structural design easily accommodates heavy product weight
- 2 sided removable header easily switched out for new marketing campaigns
- Taller bottom shelf for complementary items: chips, taco shells or beverages
- Rolling rear casters allow the display to be easily positioned in-store
- Excellent product visible
- Easy to shop & restock
- Optional plastic bag dispenser available

Header available in 5 different custom signs (see page 14).



portable display

LA0982 Salad Solutions Eco-Friendly Display

Assembled Dimension:
31.75" w x 18.25" d x 32.5" h

Fill Capacity:
2 48ct cases

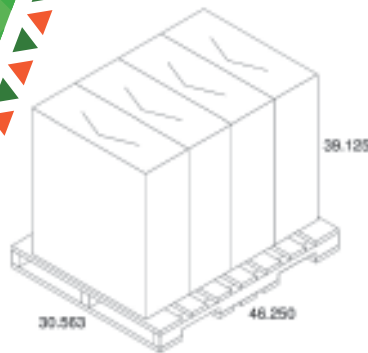

Pallet Layout

features & Specifications:

- Easy to assemble and break down for recycling in minutes
- Made from 100% recyclable corrugated material
- High density laminated fiber board extends in store life
- Robust structural design easily accommodates heavy product weight
- Removable wire rack with a large graphic panel to feature more product
- Smaller side areas to display additional produce
- Rolling rear casters allow the display to be easily positioned in-store
- Excellent product visible
- Easy to shop & restock
- Optional plastic bag dispenser available



portable display

LA0983 Salad Solutions Vac-Form Aisle Blade

Assembled Dimension:
6"w x 1"d x 18"h

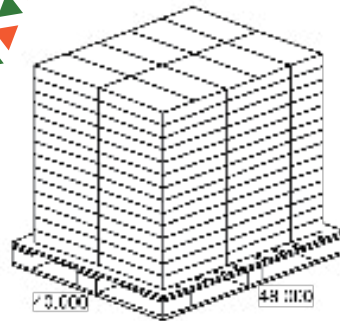

Pallet Layout



features & Specifications:

- Permanent display is durable plastic for long lasting life
- Ease of execution, simply attach clip to store fixture
- Changeable graphic panel easily switched out for new marketing campaigns
- Dynamic dimensional shape draws attention to the product
- Easily used in other areas of the store
- Excellent product visible - increases product visibility
- Reminds the shopper to include avocados to their purchase

portable display

LA0719 Avocado Bag Stand

Assembled Dimension:
14" w x 16.5" d x 56" h

Fill Capacity:
18 8-ct Bags

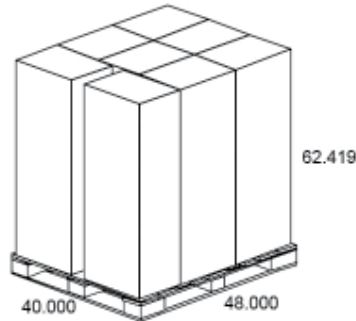

Pallet Layout

features & Specifications:

- 8 kits on 48" x 40" x 62.5" h pallet
- Permanent display is durable for long lasting life
- Ease of execution, displays arrive per-assemble, simply attach header in-store
- 2 sided removable header easily switched out for new marketing campaigns
- 2 sided removable back graphic panel easily switched out for new messaging
- Efficient footprint supports placement in high traffic areas to drive impulse sales
- Light weight compact footprint, easy to move
- Excellent product visible
- Easy to shop & restock
- Holds 18 bags of avocados



portable display

LA0729 Three Prong Fixture

Assembled Dimension:
18" w x 14.75" d x 20.5" h

Fill Capacity:
9 8-ct Bags

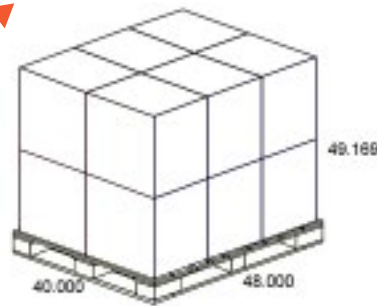

Pallet Layout

Features & Specifications:

- 12 kits on 48"x 40"x 49.25"h pallet
- Permanent display is durable for long lasting life
- Ease of execution, displays arrive per-assemble
- Pig-tail holders at top of display for optional price point or graphics signage
- Adjustable back frame to accommodate various sloped surfaces.
- Light weight compact footprint, easy to move
- Low profile won't obstruct retail sight-lines
- Excellent product visible
- Easy to shop & restock
- Holds 9 bags of avocados



portable display

LA0930 Cooler Wire Rack

Assembled Dimension:
13.75"w x 6.25"d x 7.25"h

Fill Capacity:
12



Egg



Cheese



Dairy

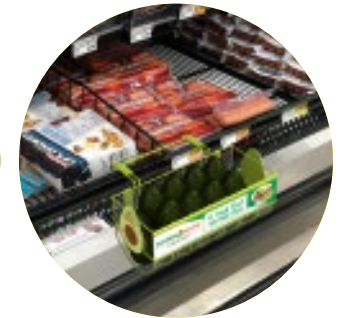

Meat

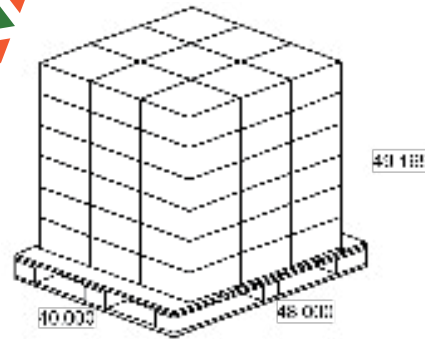

Pallet Layout



features & Specifications:

- Permanent display is durable for long lasting life
- Ease of execution, simply attach to store fixture
- Changeable graphic panel easily switched out for new marketing campaigns
- Light weight compact footprint, easily used in other areas of the store
- Excellent product visible - increases product viability
- Reminds the shopper to include avocados to their purchase
- Easy to shop & restock
- Holds 12 of avocados

portable display

LA0958 Permanent Cooler Case Bridge Extender

Assembled Dimension:
10.75"w x (adjustable) d x 2.5"h

Fill Capacity:
12

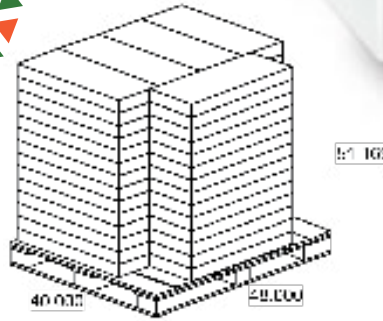

Pallet Layout



features & Specifications:

- Permanent display is durable plastic for long lasting life
- Ease of execution, simply attach clip to store fixture
- Silk-screened logo ensures AFM product are placed in the display
- Telescoping design to ensure fit on a variety of cooler case sizes
- Easily used in other areas of the store
- Excellent product visible - increases product visibility
- Reminds the shopper to include avocados to their purchase

portable display

LA0979 Farmers Market Stacking Trays

Assembled Dimension:
16.875"w x 12.75"d x 7.25"h

Fill Capacity:
1 48ct case (per tray)

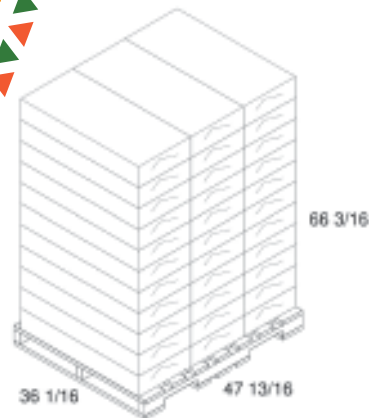

Pallet Layout

features & Specifications:

- Easy to assemble. Just insert existing avocado crate into printed tray
- Made from 100% recyclable corrugated material
- Stackable trays can be configured in any needed footprint in-store
- Locking tabs ensure a tight fit and add to stacking strength
- Excellent product visible
- Easy to shop & restock



portable display

LA0980 Farmers Market Large Bin

Assembled Dimension:
48" w x 40" d x 30.5" h

Fill Capacity:
3 - 4 48-ct Cases

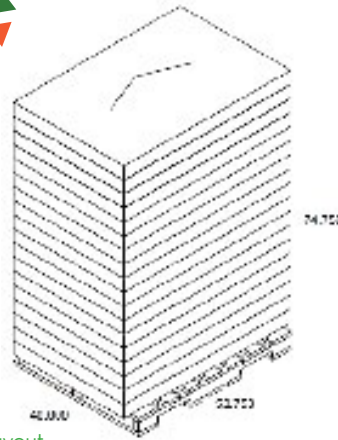

Pallet Layout

features & Specifications:

- Kit outside dims: 51.75" x 38" x 1.4375" H
- 1 kit per layer
- 45 kits per pallet (single stacked pallet)
- 70" Pallet height
- LTL (Less-Than-Truckload) shipping
- 27 kits per pallet (double stacked pallets)
- 44.83" Pallet height
- 1296 kits per truck
- 48 pallets per 53' Dry Van
- 636" L x 98" W x 110" H



portable display

LA0978 Farmers Market Rolling Cart

Assembled Dimension:
22.75" w x 34" d x 31.5" h

Fill Capacity:
4 48ct cases

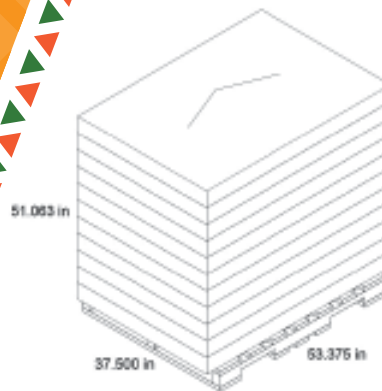

Pallet Layout



features & Specifications:

- Made from 100% recyclable corrugated material
- High density laminated fiber board extends in store life
- Utilizes existing tooling of the small avocado bin
- Locking casters located under the display allows for ease of positioning in-store
- Utilizes farmer's market style graphic for a perceived sustainable appearance
- Excellent product visible
- Easy to shop & restock
- Optional plastic bag dispenser available

educational signage

Educational Custom Headers

Available in variety of sizes to fit AFM permanent displays and in-store fixtures

HOW TO RIPEN AN AVOCADO FASTER

Avocados ^{from} Mexico
ALWAYS IN SEASON
AvocadosFromMexico.com

HOW TO CUT AN AVOCADO

Avocados ^{from} Mexico
ALWAYS IN SEASON
AvocadosFromMexico.com

A DELICIOUS ALTERNATIVE

- Naturally Good Fats
- Cholesterol Free

A NUTRITIOUS SPREAD ON SANDWICHES!

Avocados ^{from} Mexico
ALWAYS IN SEASON
AvocadosFromMexico.com

HOW TO PICK AN AVOCADO

Avocados ^{from} Mexico
ALWAYS IN SEASON
AvocadosFromMexico.com

HOW TO STORE

Avocados ^{from} Mexico
ALWAYS IN SEASON
AvocadosFromMexico.com

educational signage

Avocado Interactive Sign

Assembled Dimension:
17"W x 7"h x 1.75"d



features & Specifications:

- Innovative, fun 3D design, simulating various stages of Avocado ripeness
- Eye-catching and engaging interactive experience
- Educates customers and inspires impulse purchases
- Durable, washable High Impact Polystyrene for long lasting life
- Versatile hanging design offers flexible in store fixture implementation





Gracias!

If you have any questions
please contact your
**AFM Regional
Marketing Director**





ALWAYS
IN SEASON